

ITALIAN CLOSET HARDWARE COMPONENT PROGRAM



furnital

PMI
PETER MEIER INC



furnital

ABOUT

At PMI, we are captivated by European design. Every day, we challenge ourselves to curate specialized products that translate to the American cabinet and furniture manufacturing process. We meticulously craft, engineer, and design practical solutions that enhance the functionality of hardware and accessories. For more than 30 years, we have worked tirelessly to find solutions for the furniture, kitchen & bath, closet, hospitality and office industries.

ITALIAN CLOSET HARDWARE COMPONENT PROGRAM

We are thrilled to present our latest line of high-end Italian closet hardware and components from **furnital** tailored for walk-in closets. Merging sophistication with functionality, our new collection embodies luxury and innovation. With a focus on enhancing organization and maximizing storage efficiency, our components seamlessly integrate into diverse design aesthetics, catering to the discerning tastes of homeowners, interior designers, and architects alike. Our range offers an array of solutions to enhance any closet space.

Note: Manufacturing tolerance are based on metric dimensions. Fractions are for reference only.

TABLE OF CONTENTS

6	Technical Information
14	Walk-In Closet Components
15	Components for Walk in Closets with Back Panel
22	Shelf Brackets with Bottom Screw Mounting Lugs (25mm)
23	Shelf Brackets with Bottom Screw Mounting Lugs (36mm)
24	Shoe Rack Shelf Bracket
25	Shoe Rack Bracket with Bottom Screw Mounting Lugs
27	Ready-Made Aluminum Shelves
29	Ready-Made Aluminum Drawer Box H100/H200
32	Cabinet Rear Mount Brackets
33	Cabinet Side Mount Brackets
34	Lighting



CONTACT INFO

1255 South Park Dr.
Kernersville, NC 27284 USA
Tel. 336-996-7774
Fax 336-996-1812
Toll Free 800-222-6941
E-mail: info@petermeier.com
www.petermeier.com





WALK-IN CLOSET

TECHNICAL INFORMATION

INSTALLATION GUIDE

1 Insert the wall mount brackets

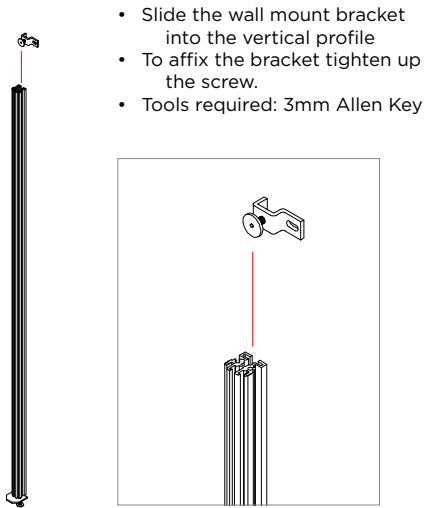

- Slide the wall mount bracket into the vertical profile
- To affix the bracket tighten up the screw.
- Tools required: 3mm Allen Key

2 Mount the first vertical wall mount profile to the wall

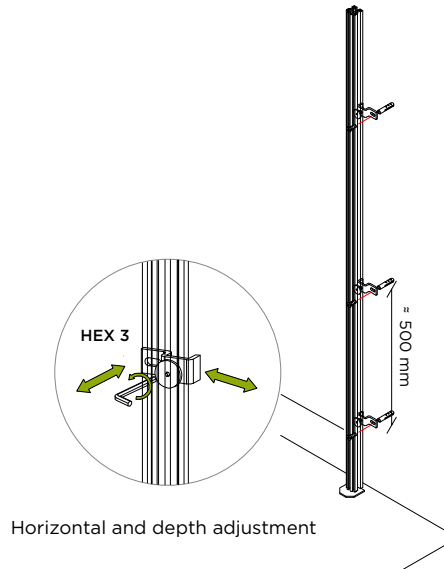

Horizontal and depth adjustment

- Mount the wall mount brackets onto the wall. It is suggested to use one bracket every 500mm.
- The quality and quantity of the screws used to affix the brackets onto the wall, along with the composition and quality of the wall, will determine the load capacity of the walk-in closet system.

3 Prepare the wooden back panel

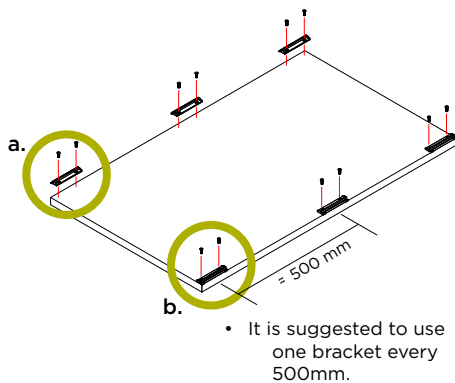

- It is suggested to use one bracket every 500mm.

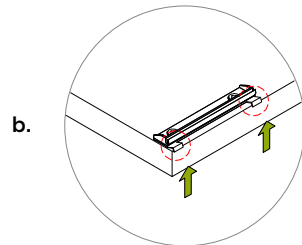
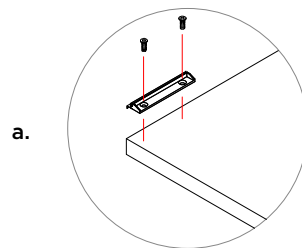

- Screw the back panel mounting clip onto the wooden back panel using #8 x 5/8" wood screws. It is suggested to predrill before fastening screws.

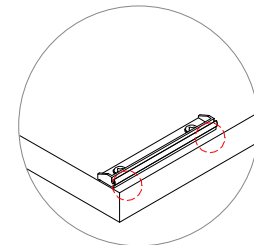

- The position of the back panel mounting clip is determined by the plastic removable tabs, which give the correct offset from the edge of the panel.

- After the clip has been installed to the panel, remove the plastic tabs from the clip with a razor knife.

4 Install the second vertical wall profile onto the wooden back panel

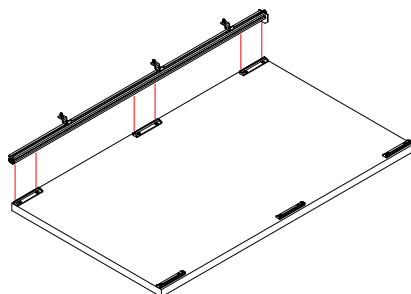

- Once the plastic tabs have been removed, you can clip the vertical wall profile with the pre-installed wall mount brackets onto the plastic clips.

5 Install the back panel with the second vertical wall mount profile to the first profile previously mounted to the wall

- Clip the first wooden back panel onto the vertical profile that has been pre-installed to the wall.

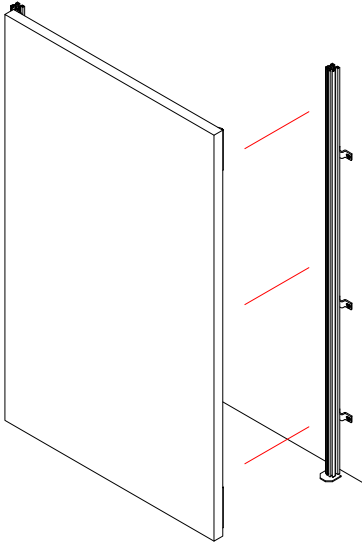

6 Repeat to mount additional back panels

- Clip the second wooden back panel onto the vertical profile mounted to the wall. The position of the next vertical profile is determined by the previously installed back panel.
- This operation can be repeated for additional panels as needed.

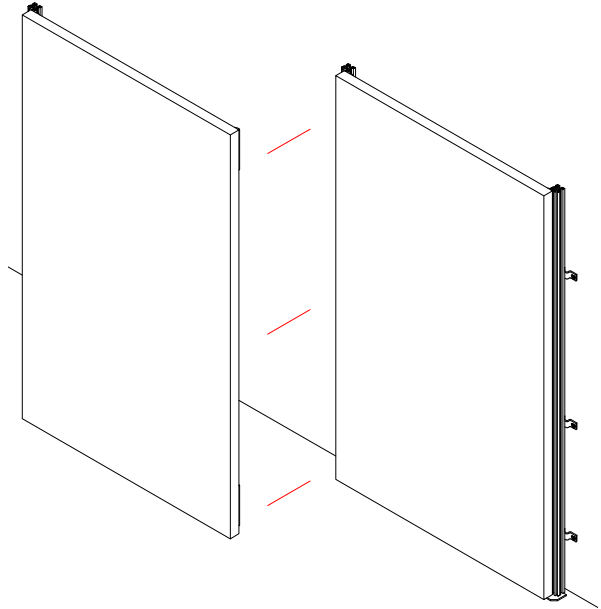

7 Attach the corner

- Mount the corner to cover the last vertical profile.

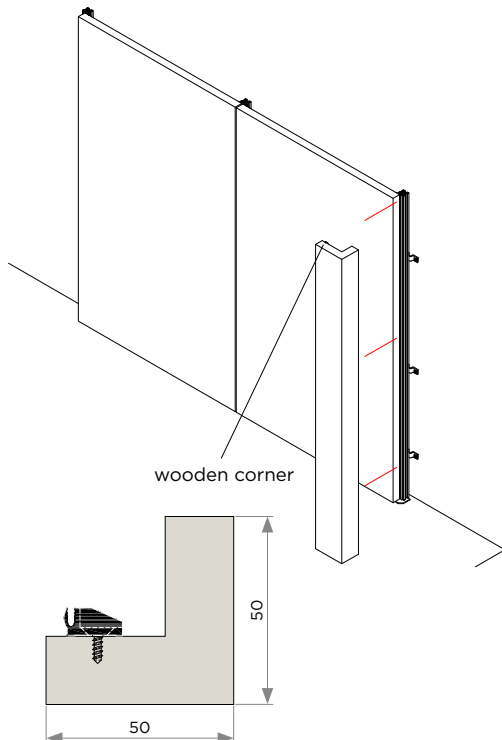

8 Adjust the system

- Adjust the height of the panels by aligning the top and bottom edges with the pre-mounted leveler assembled at the bottom of the vertical profile.
- Tools required: 13mm Wrench

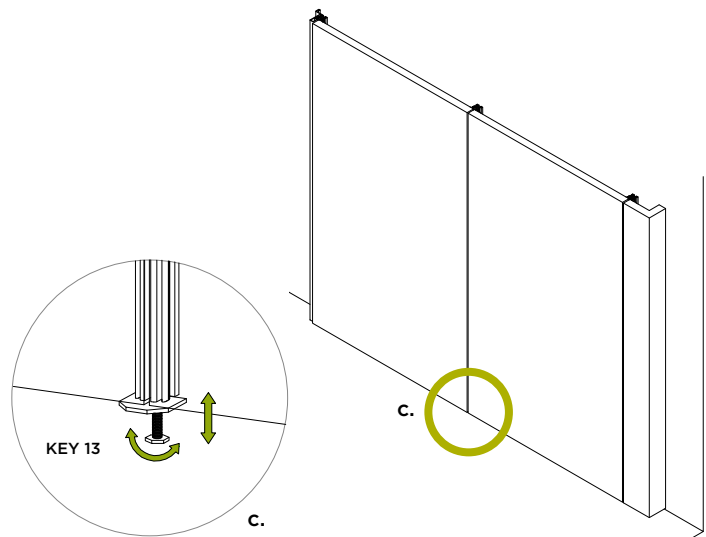

9 How to install the shelves and cabinet brackets onto the vertical profile

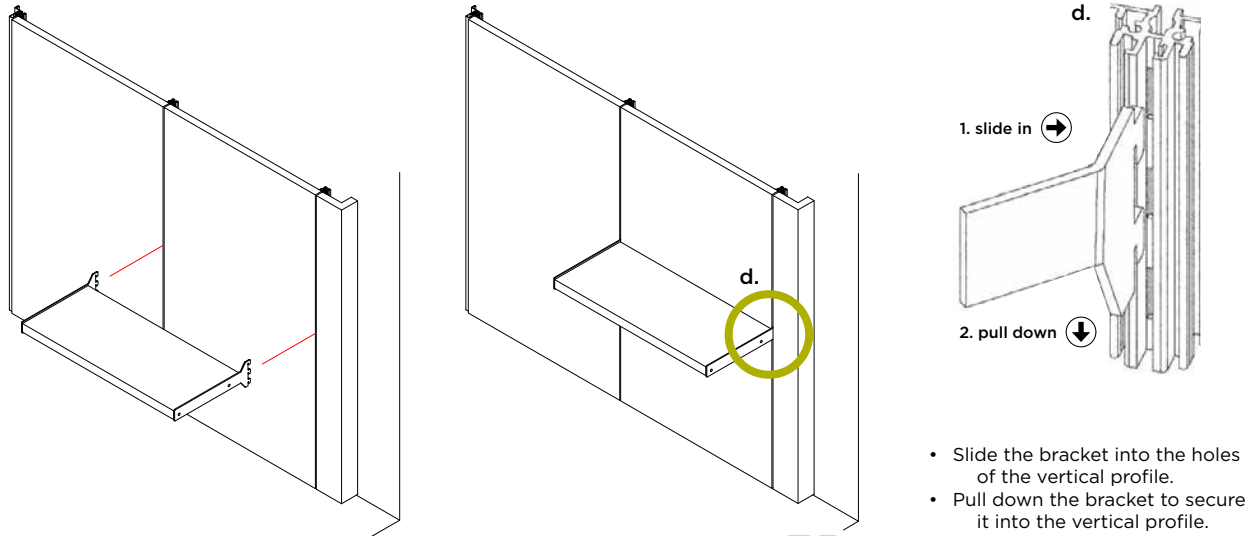

10 How to make a corner application

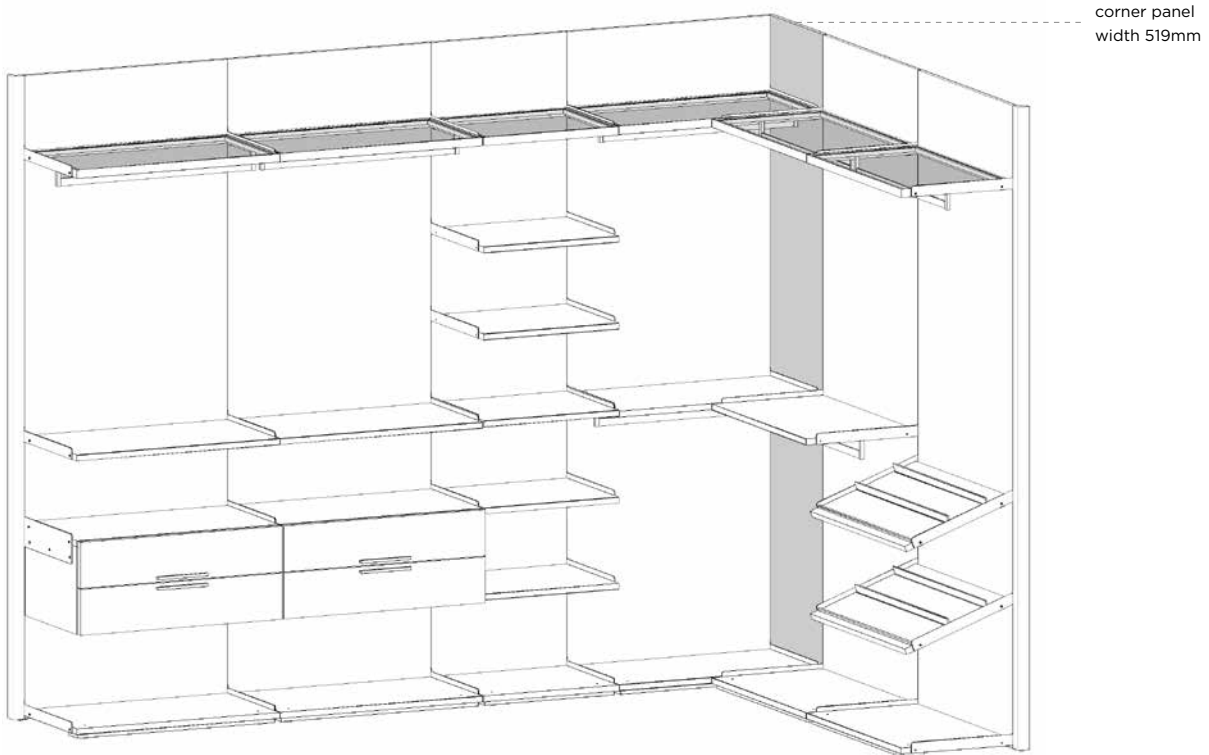

Corner detail

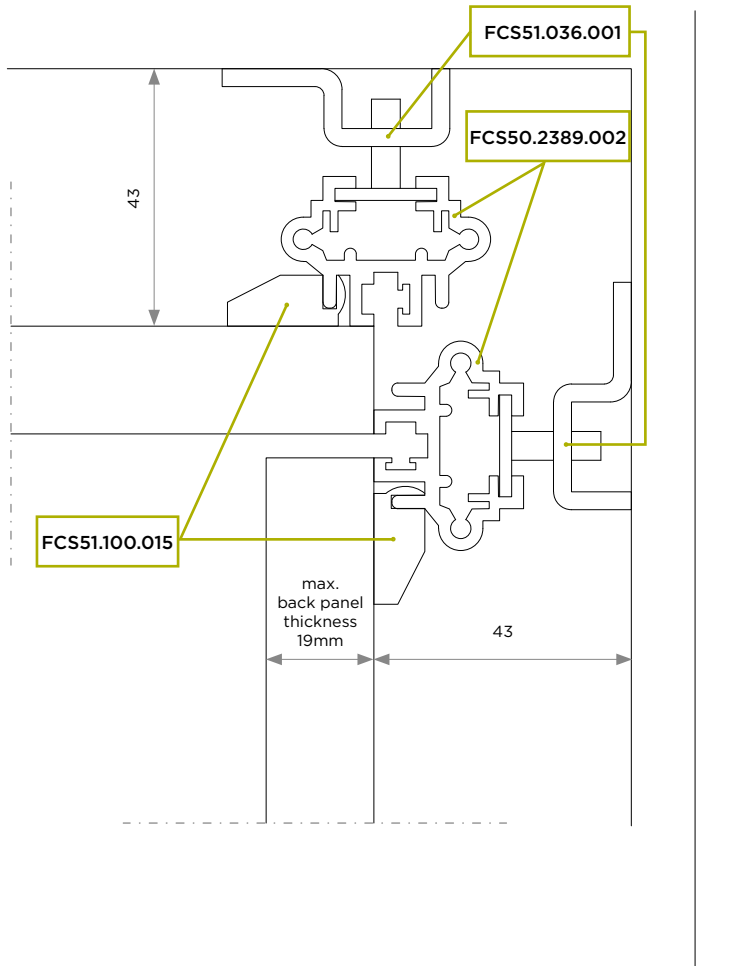

Vertical rail profile

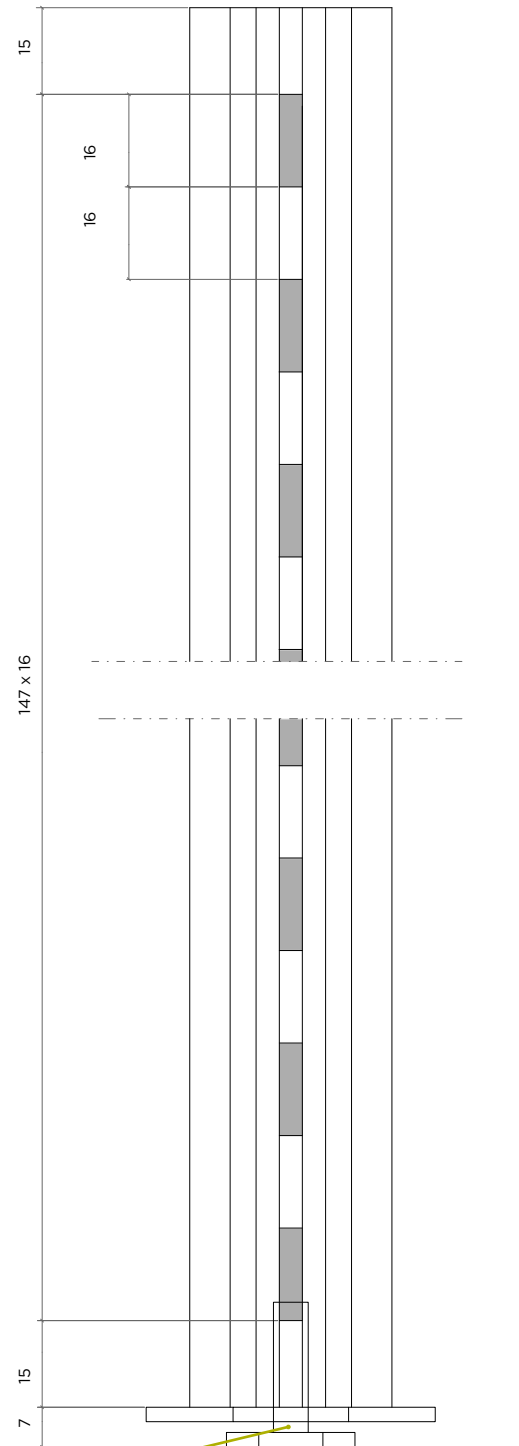

All vertical aluminum wall profiles come with a pre-installed level

AVAILABLE SHELF BRACKETS

25mm Shelf Bracket

Panel Thickness: 25mm only

for 25mm thick wood shelves | 400mm and 500mm deep

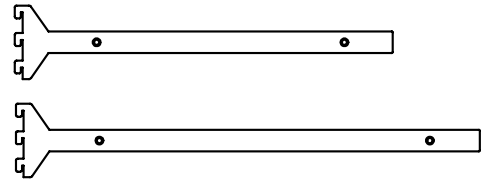

36mm Shelf Bracket

Panel Thickness: Min. 25mm / Max. 36mm

for wood or ready-made aluminum shelves | 400mm and 500mm deep

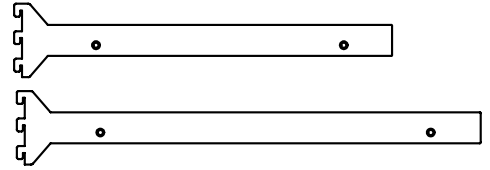

25mm Shelf Brackets with Bottom Screw Mounting Lugs

Panel Thickness: Min. 19mm / Max. 25mm

for wood shelves | 400mm and 500mm deep (left, right & center)

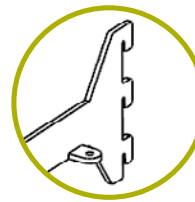

Shelf mounts with #6 wood screws

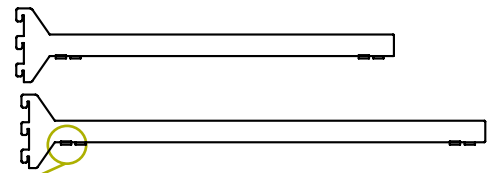

36mm Shelf Brackets with Bottom Screw Mounting Lugs

Panel Thickness: Min. 19mm / Max. 36mm

for wood shelves | 400mm and 500mm deep (left, right & center)

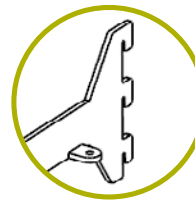

Shelf mounts with #6 wood screws

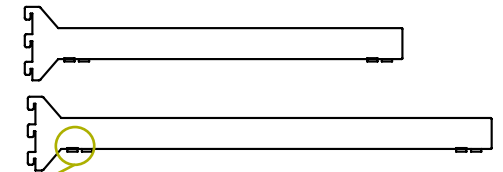

36mm Shoe Rack Shelf Bracket

Panel Thickness: Min. 25mm / Max. 36mm

for wood shelves | 400mm and 500mm deep

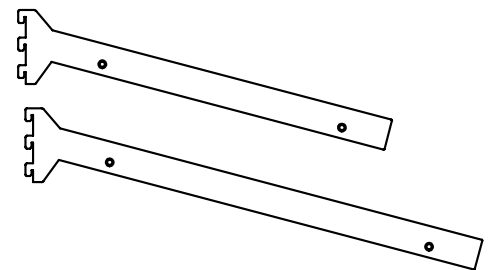

36mm Shoe Rack Shelf Bracket with Bottom Screw Mounting Lugs

Panel Thickness: 19mm / Max. 36mm

for wood shelves | 400mm and 500mm deep (left, right & center)

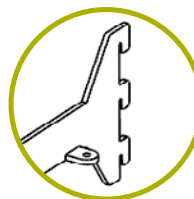

Shelf mounts with #6 wood screws

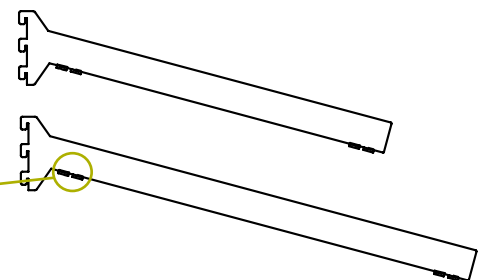

Example of Ready-Made aluminum shelves with shelf supports

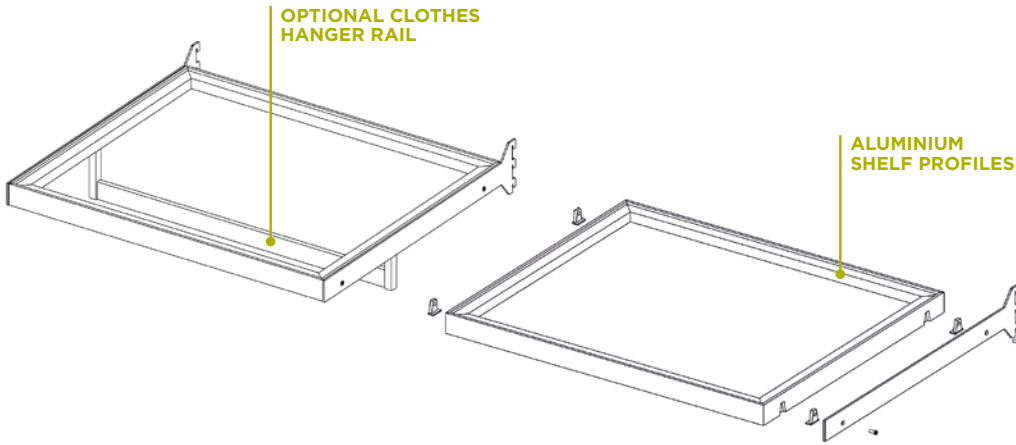

Example of wooden shelf with face drilled shelf supports

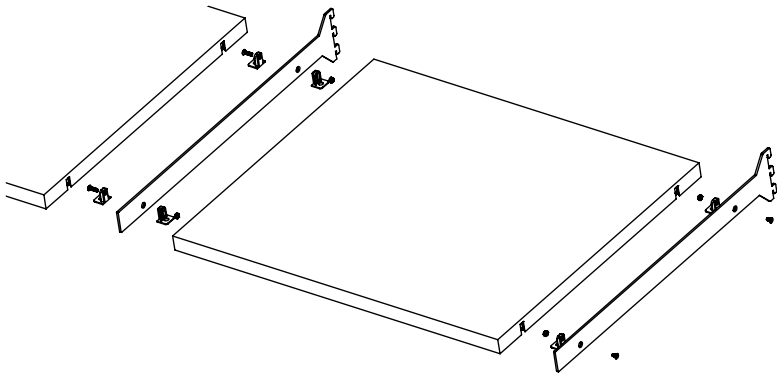

When using "Face Drilled" shelf supports, the required minimum wooden shelf thickness is 25mm.

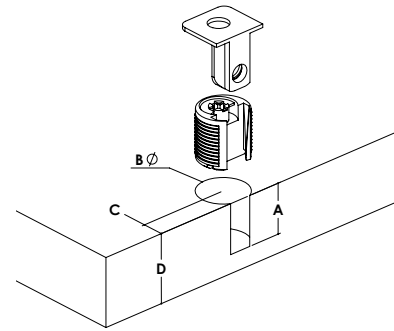

- 18.5
- ø 18
- 8
- 25

Example of wooden shelf with edge drilled shelf supports

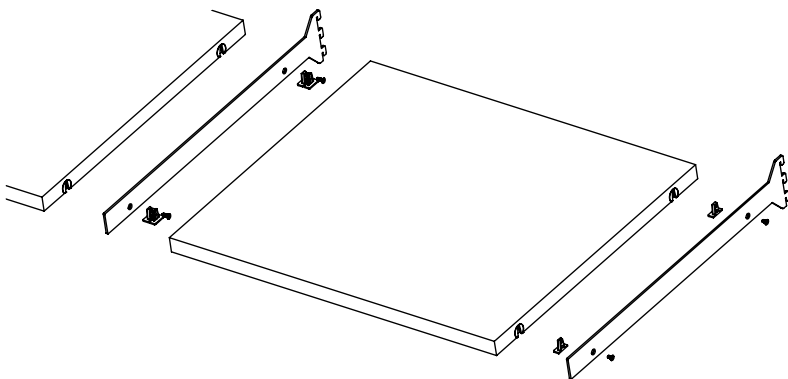

When using "Edge Drilled" shelf supports, the required minimum wooden shelf thickness is 25mm.

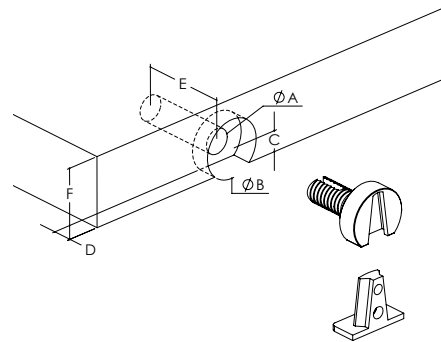

- ø 9
- ø 21
- 7.5
- 7
- 31
- 25

Example of 25mm and 36mm thick wooden shelves

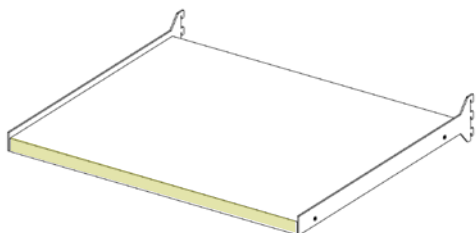

Wooden panel with thickness of 25mm

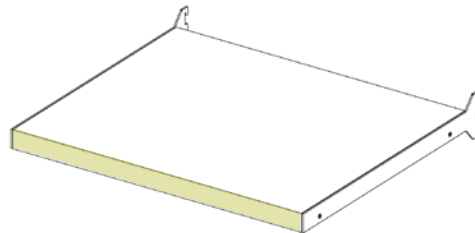

Wooden panel with thickness of 36mm

WALL MOUNT BRACKETS

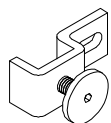

FCS51.036.001 Wall mount bracket for vertical wall mount profile with adjustment

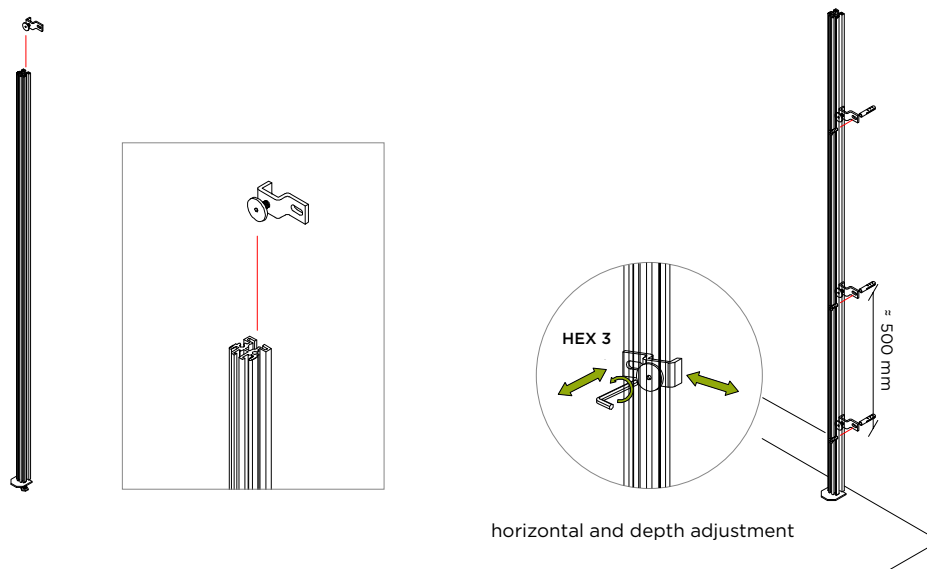

BACK PANEL MOUNTING CLIP



FCS51.100.015 Back panel mounting clip, 100x15mm
(It is suggested to use one bracket every 500mm)

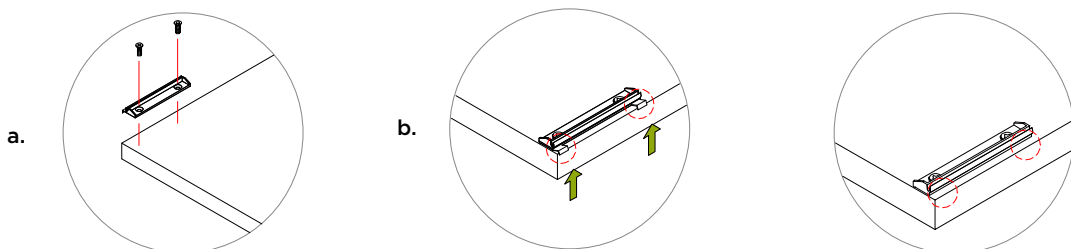

- Screw the back panel mounting clip onto the wooden back panel using #8 x 5/8" wood screws. It is suggested to predrill before fastening screws.
- The position of the back panel mounting clip is determined by the plastic removable tabs, which give the correct offset from the edge of the panel.
- After the clip has been installed to the panel, remove the plastic tabs from the clip with a razor knife.

WALK-IN CLOSET COMPONENTS

COMPONENTS FOR WALK-IN CLOSETS WITH BACK PANEL

VERTICAL ALUMINUM WALL MOUNT PROFILE WITH 4mm GAP

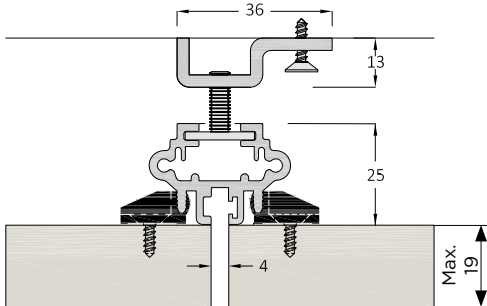

ITEM	SPECIFICATIONS	LENGTH (mm)
FCS50.2389.002	Vertical aluminum wall mounting profile	2389 [94"]

WALL MOUNT BRACKETS

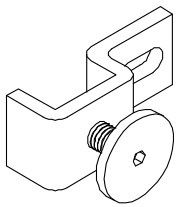

ITEM	SPECIFICATIONS
FCS51.036.001	Wall mount bracket for vertical wall mount profile with adjustment

BACK PANEL MOUNTING CLIP

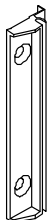

ITEM	SPECIFICATIONS
FCS51.100.015	Back panel mounting clip, 100x15mm

EXAMPLE OF SUGGESTED WOODEN CORNER END PROFILE

For vertical profile: FCS50.2414.002

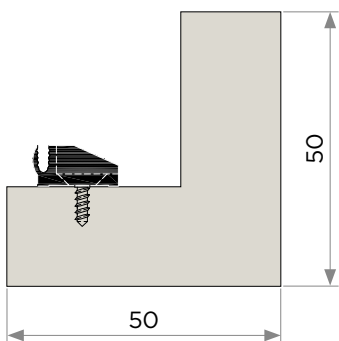

SHELF SUPPORT KITS FOR ALUMINUM READY-MADE SHELVES

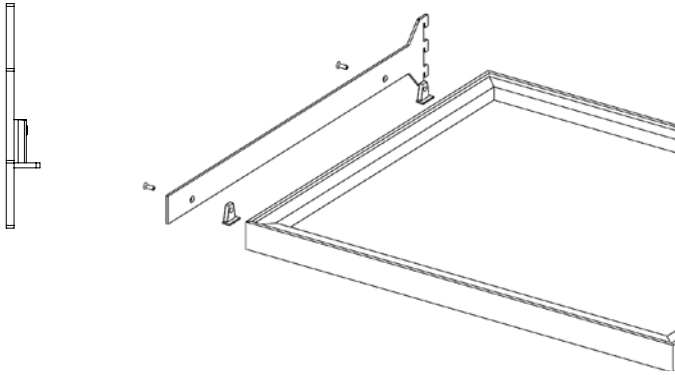

END BRACKET MOUNTING

ITEM	SPECIFICATIONS
FCS60.001.001	Kit includes: (2) Shelf Supports with Thread (2) M4x8 Black Oxide Screws

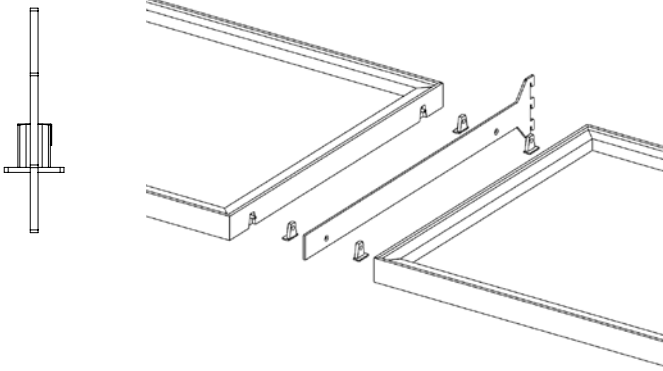
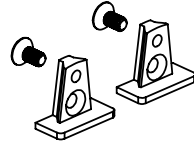

CENTER BRACKET MOUNTING

ITEM	SPECIFICATIONS
FCS60.002.001	Kit Includes: (2) Shelf Supports with Thread (2) Shelf Supports with Passing Hole (2) M4x12 Black Oxide Screws

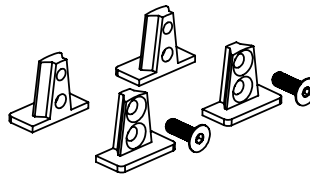

Notching Details

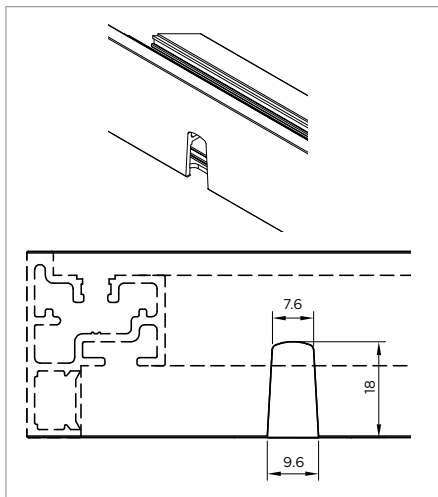

Side View

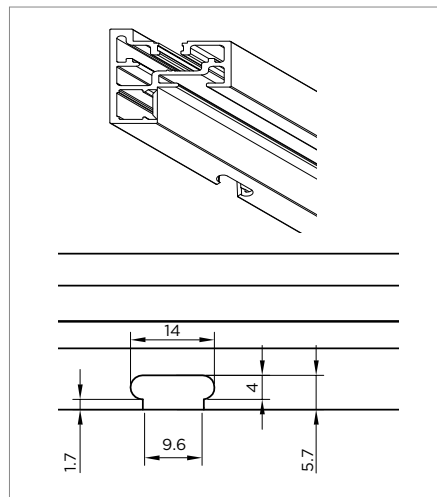

Bottom View

SHELF SUPPORT KITS FOR FACE DRILLED WOODEN SHELVES
25mm MIN. PANEL THICKNESS

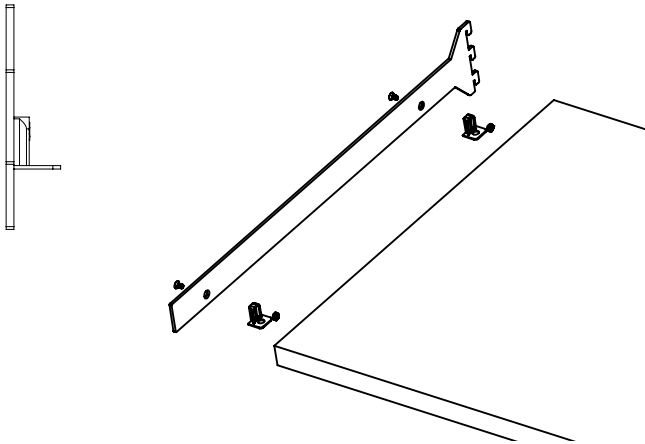

END BRACKET MOUNTING

ITEM	SPECIFICATIONS
FCS60.006.104	Kit Includes: (2) Shelf Supports for Face Drilled Panels (2) Plastic Face Drilled Inserts (2) M4 Nuts (2) M4x8 Black Oxide Screws

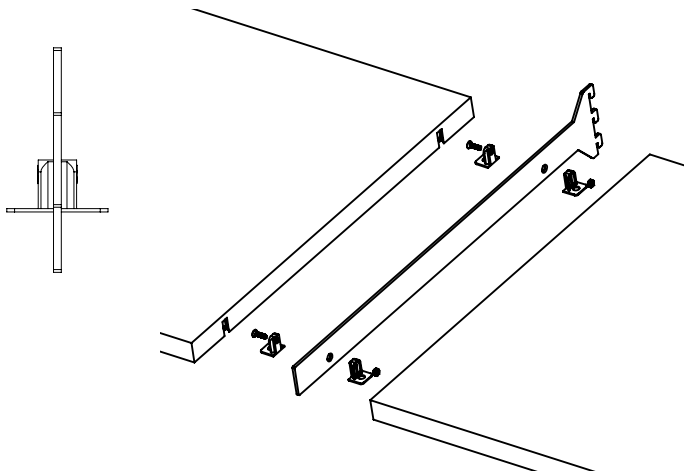
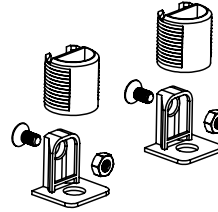

CENTER BRACKET MOUNTING

ITEM	SPECIFICATIONS
FCS60.007.104	Kit Includes: (4) Shelf Supports for Face Drilled Panels (4) Plastic Face Drilled Inserts (2) M4 Nuts (2) M4x12 Black Oxide Screws

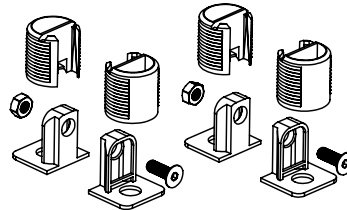

Face Boring Details

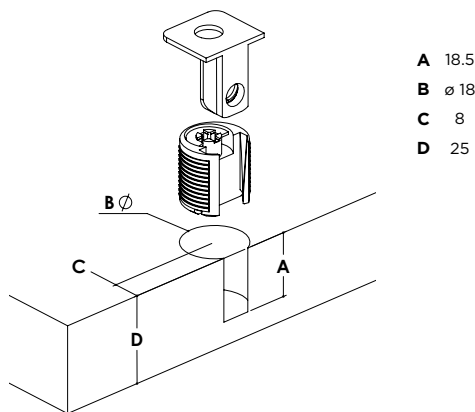

SHELF SUPPORT KITS FOR EDGE DRILLED WOODEN SHELVES

25mm MIN. PANEL THICKNESS

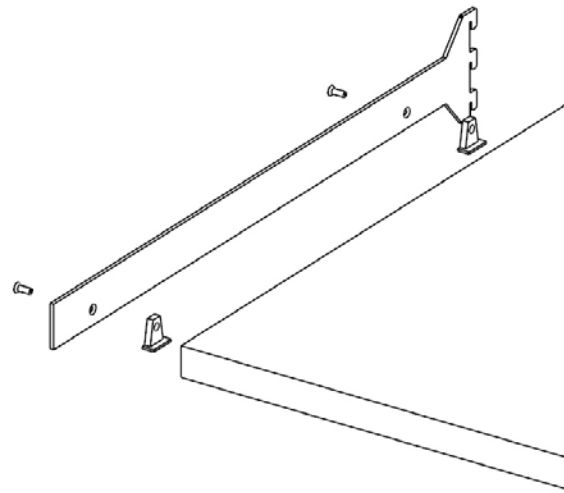

END BRACKET MOUNTING

ITEM	SPECIFICATIONS
FCS60.003.001	Kit includes: (2) Shelf Supports with Thread (2) Plastic Edge Drilled Inserts (2) M4x8 Black Oxide Screws

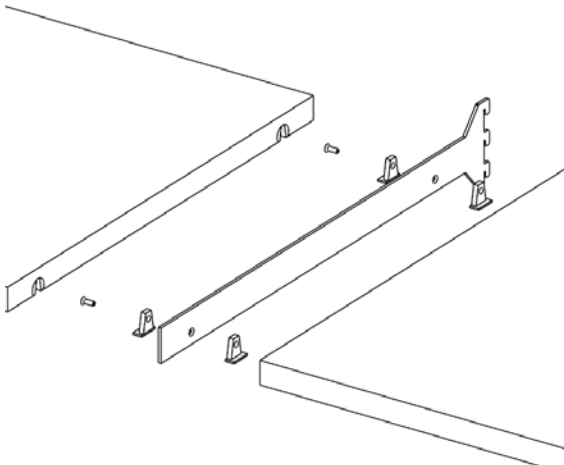
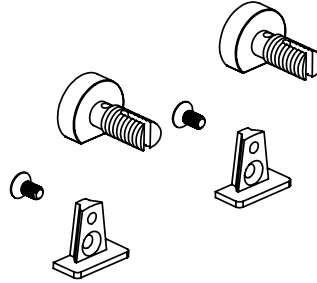

CENTER BRACKET MOUNTING

ITEM	SPECIFICATIONS
FCS60.004.001	Kit Includes: (2) Shelf Supports with Thread (2) Shelf Supports with Passing Hole (4) Plastic Edge Drilled Inserts (2) M4x12 Black Oxide Screws

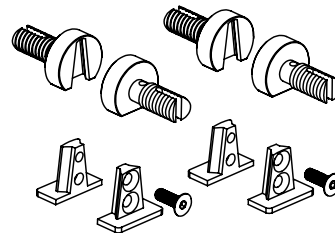

Edge Boring Details

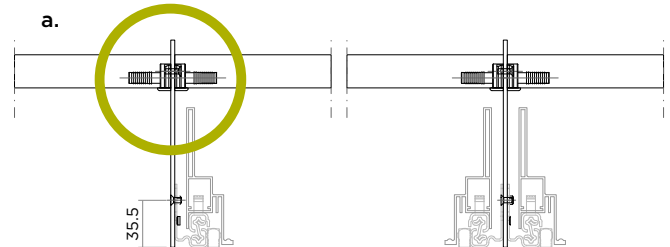
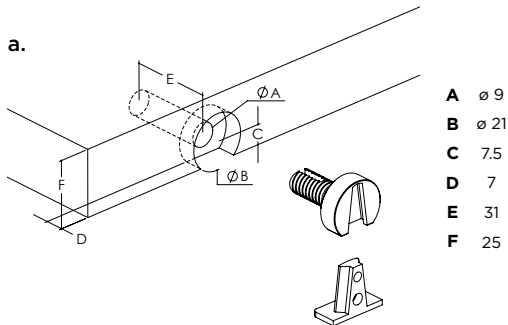



SHELF SUPPORT KITS FOR READY-MADE ALUMINUM & EDGE DRILLED WOODEN SHELF COMBINATIONS

WOODEN SHELF PANEL - 25mm MIN. PANEL THICKNESS

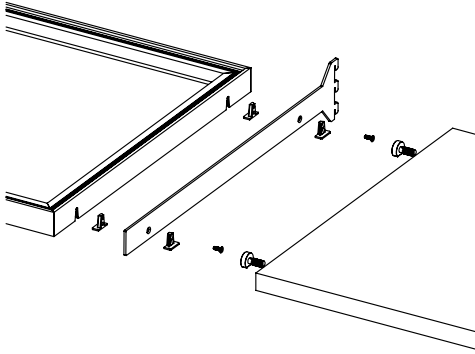

CENTER BRACKET MOUNTING

ITEM	SPECIFICATIONS
FCS60.005.001	Kit includes: (2) Shelf Supports with Thread (2) Shelf Supports with Passing Hole (2) Plastic Edge Drilled Inserts (2) M4x12 Black Oxide Screws

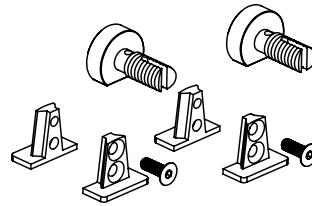

SHELF SUPPORT KITS FOR READY-MADE ALUMINUM & FACE DRILLED WOODEN SHELF COMBINATIONS

WOODEN SHELF PANEL - 25mm MIN. PANEL THICKNESS

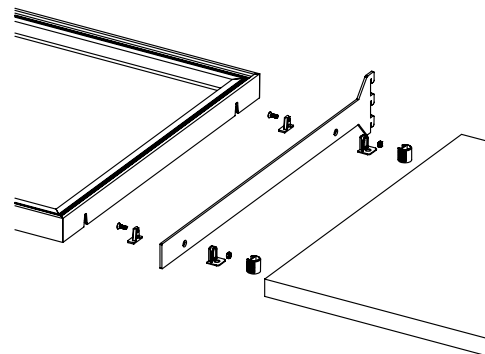

CENTER BRACKET MOUNTING

ITEM	SPECIFICATIONS
FCS60.008.104	Kit Includes: (2) Shelf Supports with Passing Hole (2) Shelf Supports for Face Drilled Panels (2) Plastic Face Drilled Inserts (2) M4 Nuts (2) M4x12 Black Oxide Screws

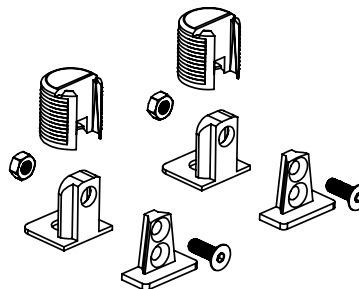

SHELF BRACKETS FOR READY-MADE ALUMINUM OR WOOD SHELVES

36mm TALL SHELF BRACKET

**SHELF DEPTH
400(mm)**

X	Y	Z
288	12.5	56

**SHELF DEPTH
500(mm)**

X	Y	Z
384	12.5	58

ITEM	FINISH	Shelf Depth (mm)
FCS61.40036.105	Brown Metal Grey	400

ITEM	FINISH	Shelf Depth (mm)
FCS61.50036.105	Brown Metal Grey	500

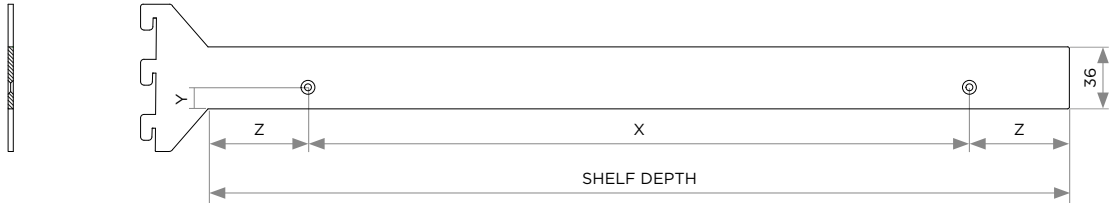

SHELF BRACKETS FOR 25mm WOOD SHELVES

25mm TALL SHELF BRACKET

**SHELF DEPTH
400(mm)**

X	Y	Z
288	12.5	56

**SHELF DEPTH
500(mm)**

X	Y	Z
384	12.5	58

ITEM	FINISH	Shelf Depth (mm)
FCS61.40025.105	Brown Metal Grey	400

ITEM	FINISH	Shelf Depth (mm)
FCS61.50025.105	Brown Metal Grey	500

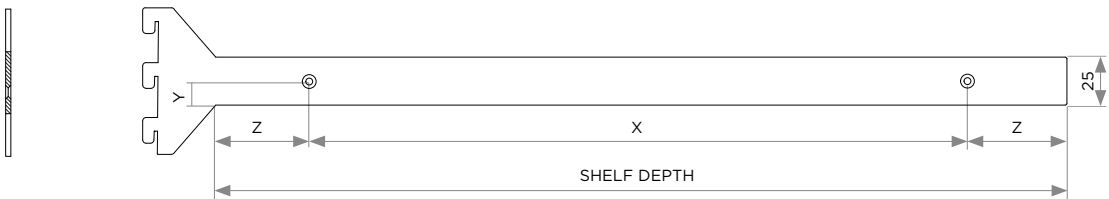

SHELF BRACKETS WITH BOTTOM SCREW MOUNTING LUGS

25mm TALL SHELF BRACKET

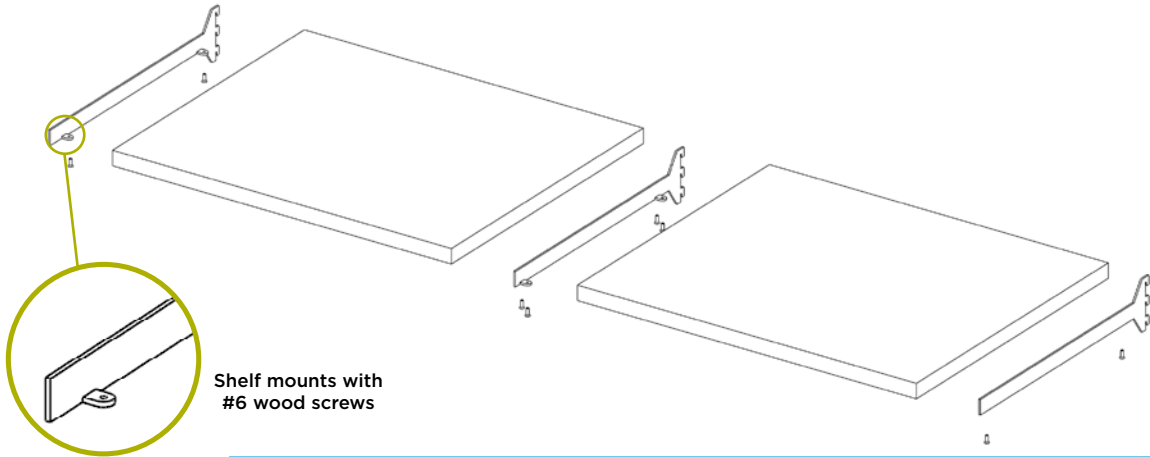

Shelf mounts with #6 wood screws

ITEM	SIDE	FINISH	SHELF DEPTH (mm)	PANEL THICKNESS (mm)
------	------	--------	------------------	----------------------

FCS62L.40025.105	Left	Brown Metal Grey	400	Min. 19 / Max. 25
FCS62L.50025.105	Left	Brown Metal Grey	500	Min. 19 / Max. 25

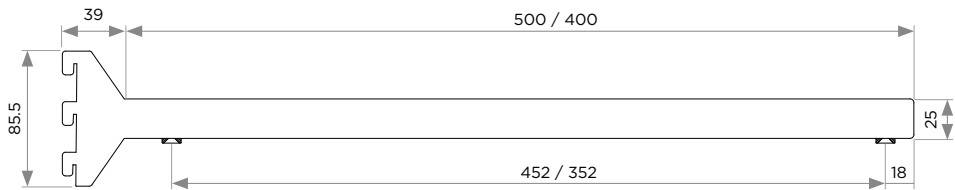
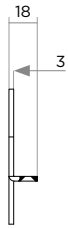

ITEM	SIDE	FINISH	SHELF DEPTH (mm)	PANEL THICKNESS (mm)
------	------	--------	------------------	----------------------

FCS62R.40025.105	Right	Brown Metal Grey	400	Min. 19 / Max. 25
FCS62R.50025.105	Right	Brown Metal Grey	500	Min. 19 / Max. 25

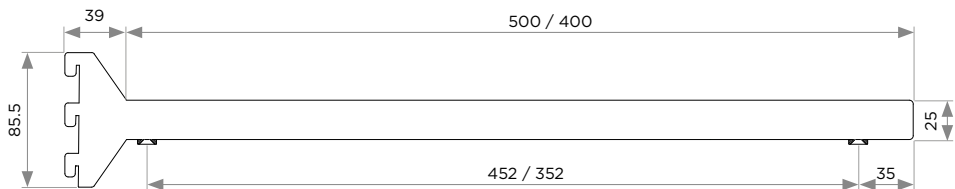
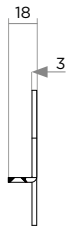

ITEM	SIDE	FINISH	SHELF DEPTH (mm)	PANEL THICKNESS (mm)
------	------	--------	------------------	----------------------

FCS62C.40025.105	Center	Brown Metal Grey	400	Min. 19 / Max. 25
FCS62C.50025.105	Center	Brown Metal Grey	500	Min. 19 / Max. 25

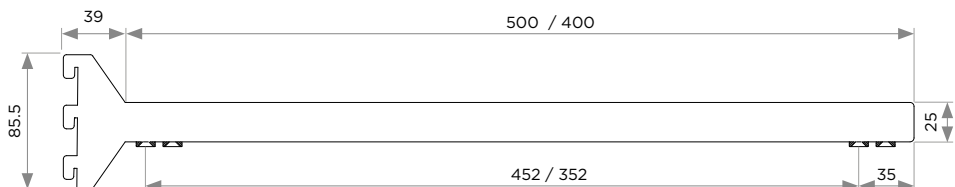
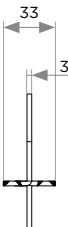

SHELF BRACKETS WITH BOTTOM SCREW MOUNTING LUGS

36mm TALL SHELF BRACKET

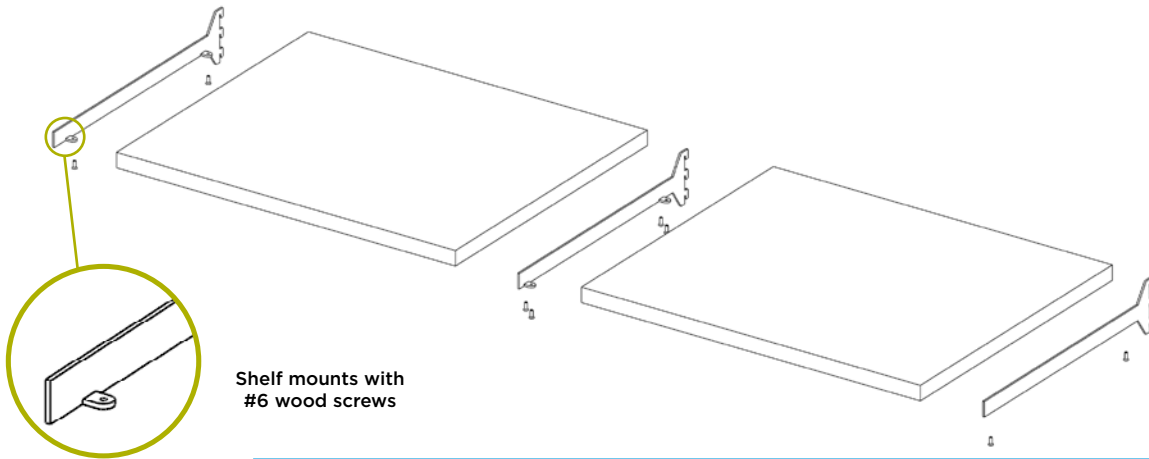

Shelf mounts with #6 wood screws

ITEM	SIDE	FINISH	SHELF DEPTH (mm)	PANEL THICKNESS (mm)
------	------	--------	------------------	----------------------

FCS62L.40036.105	Left	Brown Metal Grey	400	Min. 19 / Max. 36
FCS62L.50036.105	Left	Brown Metal Grey	500	Min. 19 / Max. 36

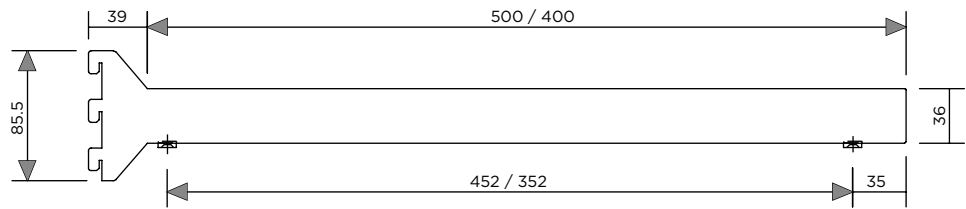

ITEM	SIDE	FINISH	SHELF DEPTH (mm)	PANEL THICKNESS (mm)
------	------	--------	------------------	----------------------

FCS62R.40036.105	Right	Brown Metal Grey	400	Min. 19 / Max. 36
FCS62R.50036.105	Right	Brown Metal Grey	500	Min. 19 / Max. 36

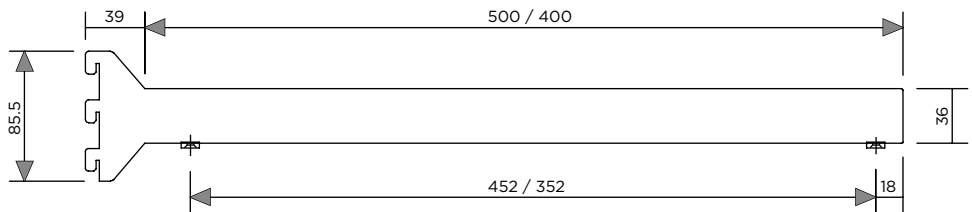
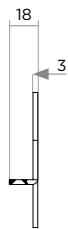

ITEM	SIDE	FINISH	SHELF DEPTH (mm)	PANEL THICKNESS (mm)
------	------	--------	------------------	----------------------

FCS62C.40036.105	Center	Brown Metal Grey	400	Min. 19 / Max. 36
FCS62C.50036.105	Center	Brown Metal Grey	500	Min. 19 / Max. 36

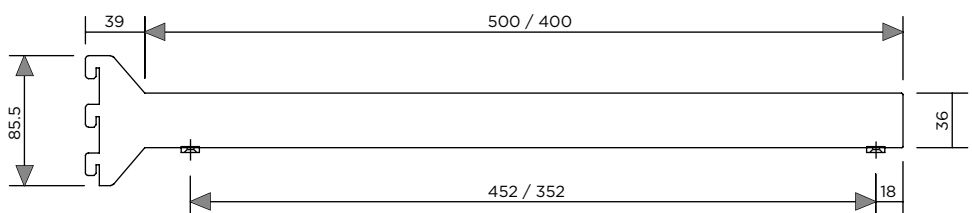
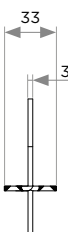

SHOE RACK SHELF BRACKET

36mm TALL SHELF BRACKET

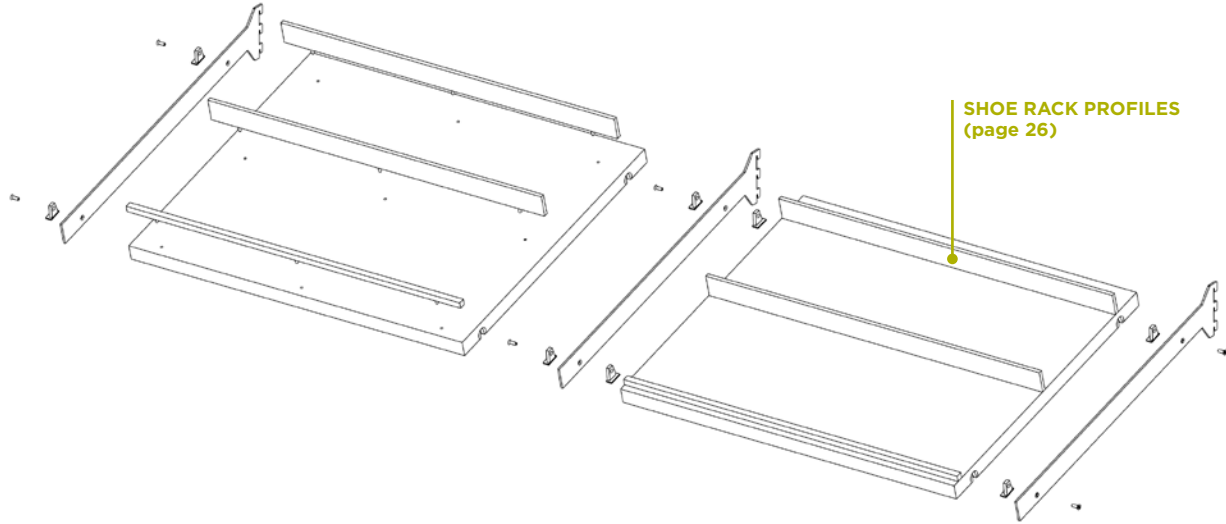

SHELF DEPTH
400(mm)

X	Y	Z
288	12.5	56

SHELF DEPTH
500(mm)

X	Y	Z
384	12.5	58

ITEM	FINISH	SHELF DEPTH (mm)
FCS63.40036.105	Brown Metal Grey	400
FCS63.50036.105	Brown Metal Grey	500

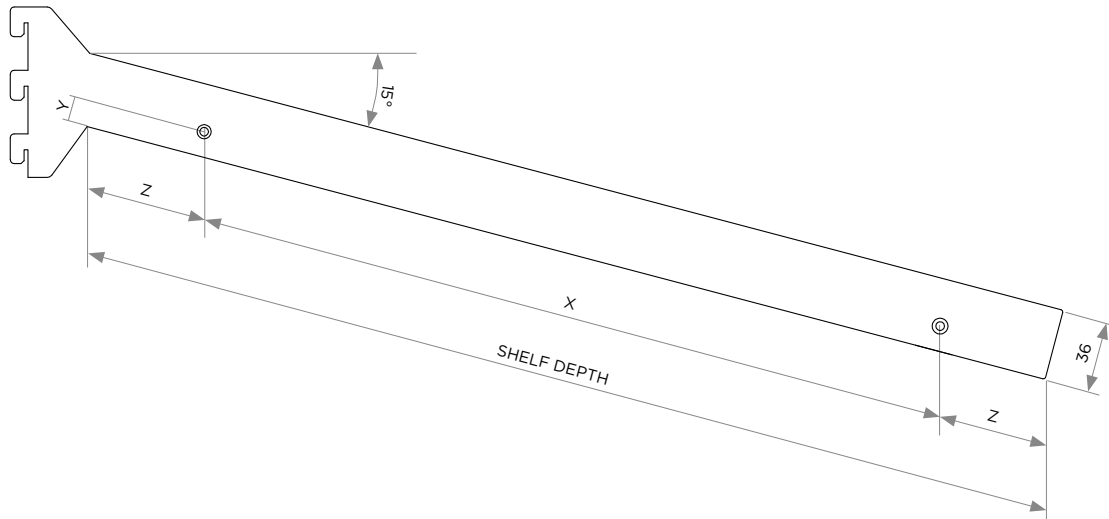

SHOE RACK SHELF BRACKET WITH BOTTOM SCREW MOUNTING LUGS

36mm TALL SHELF BRACKET

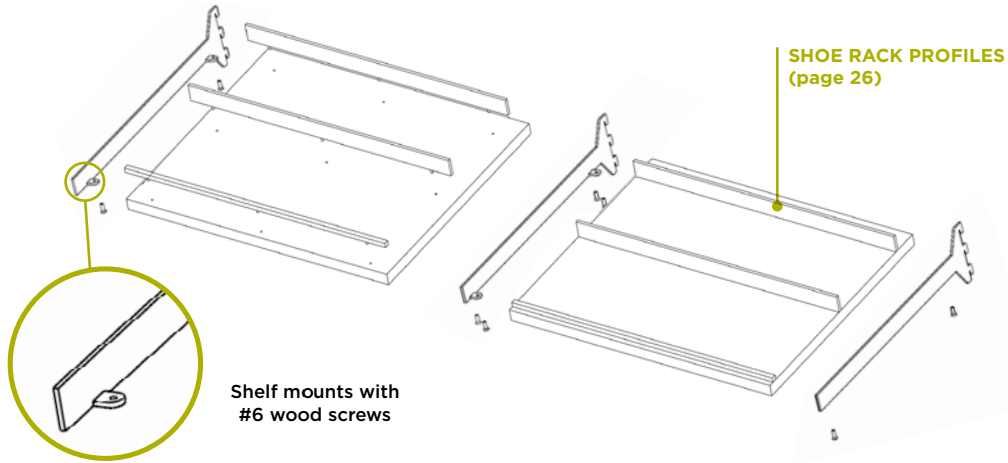

ITEM	SIDE	FINISH	SHELF DEPTH (mm)	PANEL THICKNESS (mm)
FCS63L.40036.105	Left	Brown Metal Grey	400	36 Max.
FCS63L.50036.105	Left	Brown Metal Grey	500	36 Max.

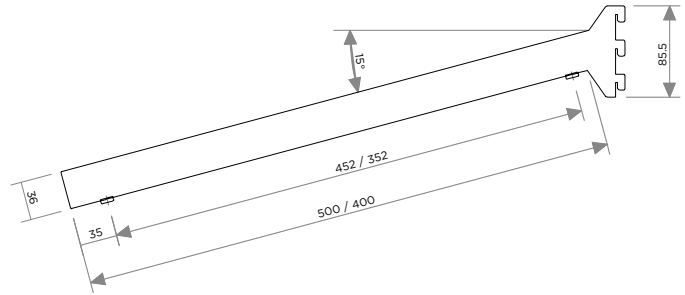

ITEM	SIDE	FINISH	SHELF DEPTH (mm)	PANEL THICKNESS (mm)
FCS63R.40036.105	Right	Brown Metal Grey	400	36 Max.
FCS63R.50036.105	Right	Brown Metal Grey	500	36 Max.

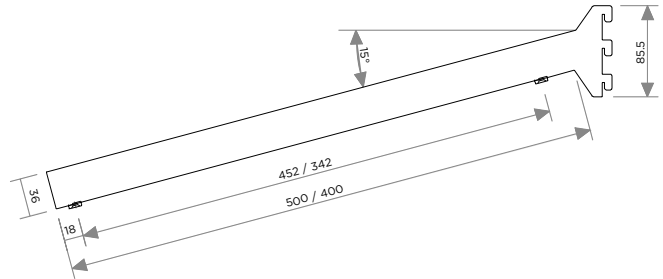

ITEM	SIDE	FINISH	SHELF DEPTH (mm)	PANEL THICKNESS (mm)
FCS63C.40036.105	Center	Brown Metal Grey	400	36 Max.
FCS63C.50036.105	Center	Brown Metal Grey	500	36 Max.

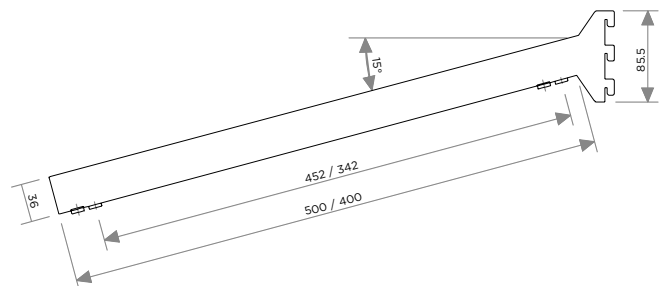

BOTTOM VIEW OF THE SCREW MOUNTING LUGS

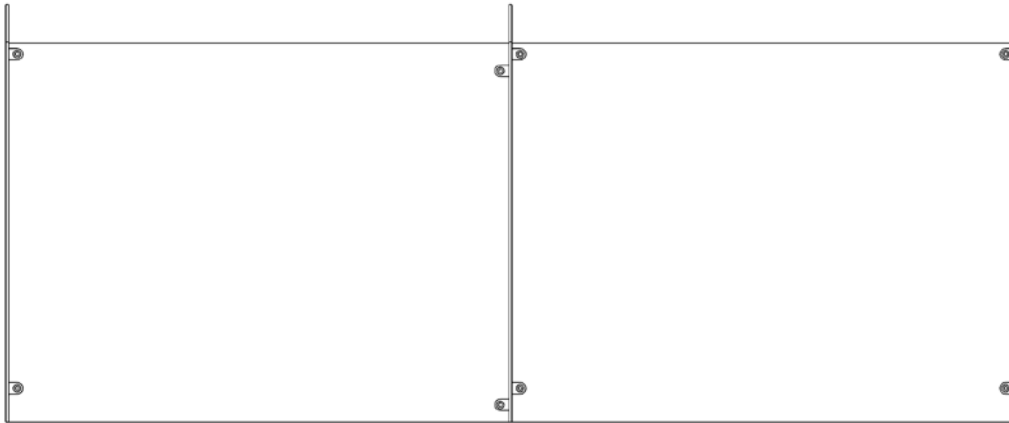

ALUMINUM SHOE RACK PROFILES

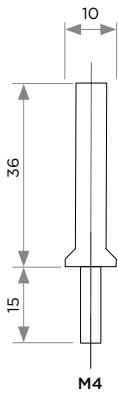

Drill $\varnothing 4$ mm mounting holes
Profiles to be installed with
glue or caulk.

ITEM	SPECIFICATIONS	FINISH	SHELF WIDTH (mm)
FCS64.58036.105	Tall Profile Length 580mm	Brown Metal Grey	600
FCS64.88036.105	Tall Profile Length 880mm	Brown Metal Grey	900

* Other lengths are available on request.

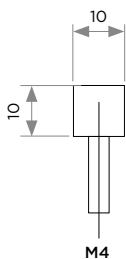
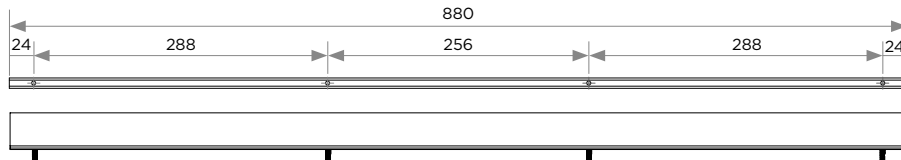
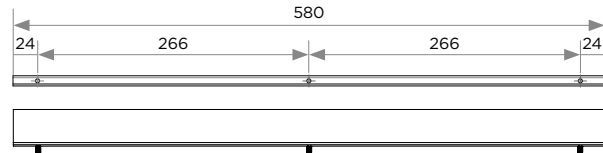

Drill $\varnothing 4$ mm mounting holes
Profiles to be installed with
glue or caulk.

ITEM	SPECIFICATIONS	FINISH	SHELF WIDTH (mm)
FCS64.58010.105	Short Profile Length 580mm	Brown Metal Grey	600
FCS64.88010.105	Short Profile Length 880mm	Brown Metal Grey	900

* Other lengths are available on request.

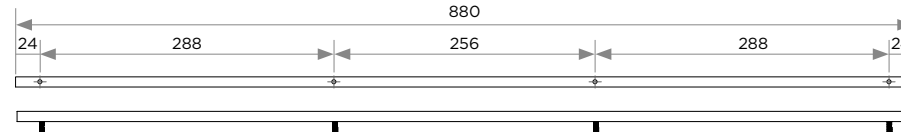
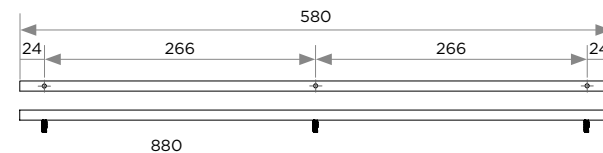

READY-MADE ALUMINUM SHELVES

MOUNTS WITH 36mm SHELF BRACKETS (page 21)

READY-MADE ALUMINUM SHELVES

(support brackets and supports sold separately, panel insert not included)

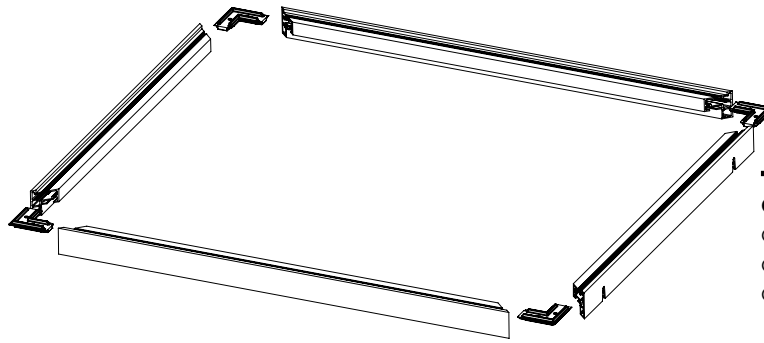
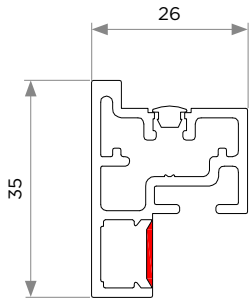
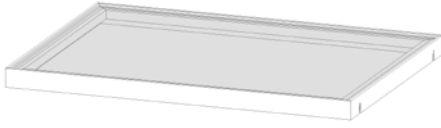

GLASS DIMENSION:
 OVERALL SHELF DEPTH MINUS 11mm
 OVERALL SHELF WIDTH MINUS 11mm
 GLASS THICKNESS 4mm

ITEM	SPECIFICATIONS	FINISH	DIMENSIONS (mm)	PANEL INSERT SIZE (mm)
FCS70.6040.105	Module Width 600	Brown Metal Grey	600 x 400 x 35	589 x 389
FCS70.9040.105	Module Width 900	Brown Metal Grey	900 x 400 x 35	889 x 489
FCS70.6050.105	Module Width 600	Brown Metal Grey	600 x 500 x 35	589 x 489
FCS70.9050.105	Module Width 900	Brown Metal Grey	900 x 500 x 35	889 x 489

READY-MADE ALUMINUM SHELVES WITH CLOTHES HANGING RAIL

(support brackets and supports sold separately, panel insert not included)

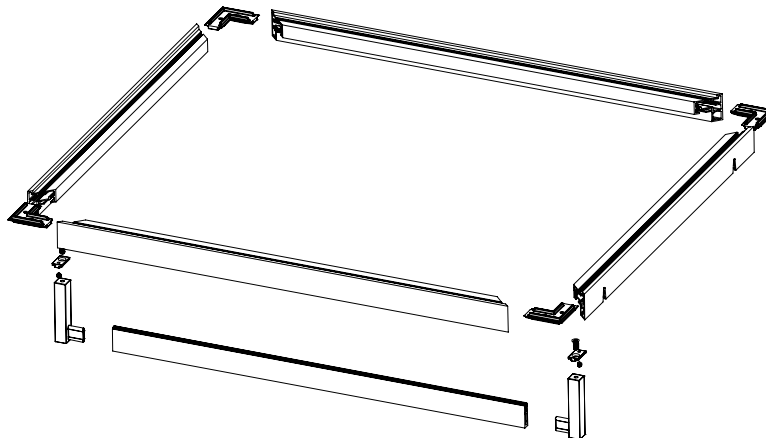
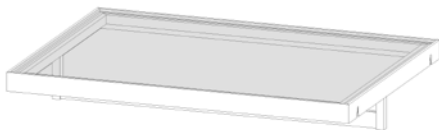

ITEM	SPECIFICATIONS	FINISH	DIMENSIONS (mm)	PANEL INSERT SIZE (mm)
FCS71.6040.105	Module Width 600	Brown Metal Grey	600 x 400 x 35	589 x 389
FCS71.9040.105	Module Width 900	Brown Metal Grey	900 x 400 x 35	889 x 489
FCS71.6050.105	Module Width 600	Brown Metal Grey	600 x 500 x 35	589 x 489
FCS71.9050.105	Module Width 900	Brown Metal Grey	900 x 500 x 35	889 x 489

CLOTHES HANGING RAIL PROFILE - 30mm x 8mm

WITH RUBBER PROTECTIVE STRIP

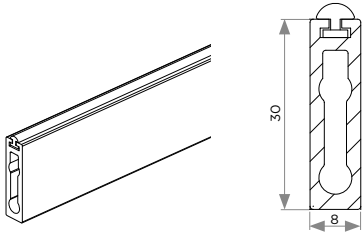

ITEM	SPECIFICATIONS	FINISH	DIMENSIONS (mm)
FCS40.549.105	Module Width 600	Brown Metal Grey	549 x 30 x 8
FCS40.849.105	Module Width 900	Brown Metal Grey	849 x 30 x 8

SET OF CLOTHES HANGING RAIL END SUPPORTS

INSERT MOUNTED FROM SHELF BOTTOM

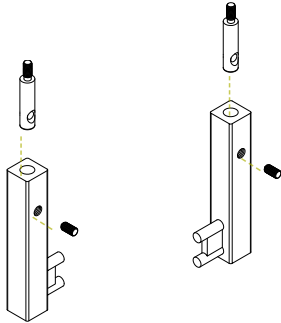

ITEM	SPECIFICATIONS	FINISH	DIMENSIONS (mm)
FCS41.004.105	M6 Pin Thread and Conic Set Screw	Brown Metal Grey	15 x 15 x 80

(M6 inserts not included)

CLOTHES HANGING RAIL END SUPPORT

THRU-BOLT THROUGH SHELF PANEL

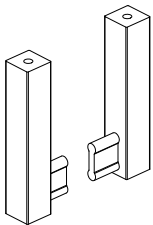

ITEM	SPECIFICATIONS	FINISH	DIMENSIONS (mm)
FCS41.002.105	Thru-Bolt	Brown Metal Grey	15 x 15 x 80

Sold as Each, M5 Screws not included.

CLOTHES HANGING RAIL CENTER SUPPORT

THRU-BOLT THROUGH SHELF PANEL

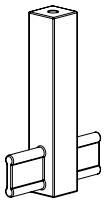

ITEM	SPECIFICATIONS	FINISH	DIMENSIONS (mm)
FCS41.003.105	Thru-Bolt	Brown Metal Grey	15 x 15 x 80

M5 Screws not included.

CLOTHES HANGING RAIL CONNECTOR FOR READY-MADE ALUMINUM SHELVES

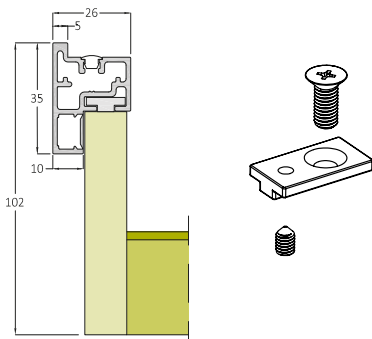

ITEM	SPECIFICATIONS	FINISH	DIMENSIONS (mm)
FCS41.001.101	For Ready-Made Aluminum Shelves	Black Zinc	15 x 15 x 80

READY-MADE ALUMINUM DRAWER BOX H100/H200

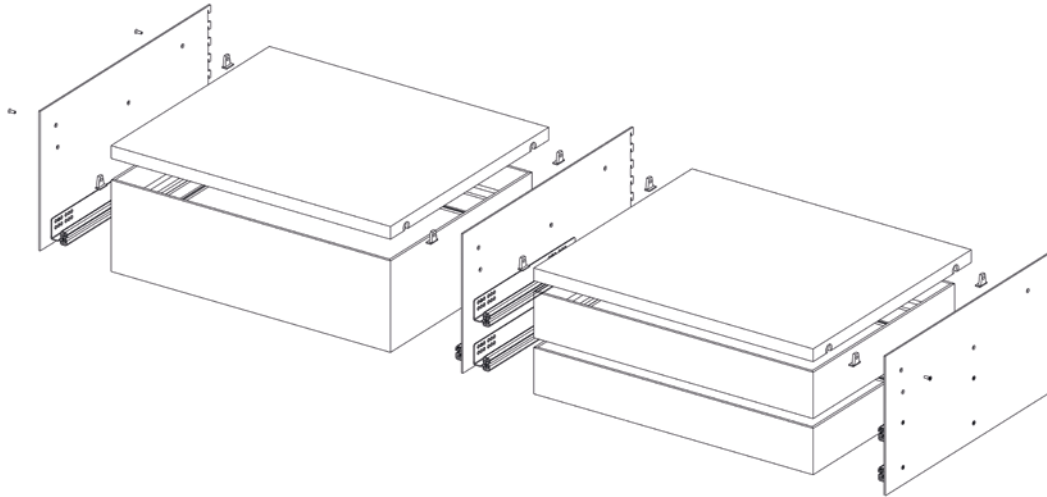

H100 DRAWER BOX WITH PRE-MOUNTED CLIP FOR SLIDES (slides sold separately, drawer bottom not included)



ITEM	SPECIFICATIONS	FINISH	DIMENSIONS (mm)	DRAWER BOTTOM SIZE (mm)
FCS80.6010.105	Module Width 600	Brown Metal Grey	583 x 448 x 103	525 x 390
FCS80.9010.105	Module Width 900	Brown Metal Grey	883 x 448 x 103	825 x 390

H200 DRAWER BOX WITH PRE-MOUNTED CLIP FOR SLIDES (slides sold separately, drawer bottom not included)



ITEM	SPECIFICATIONS	FINISH	DIMENSIONS (mm)	DRAWER BOTTOM SIZE (mm)
FCS80.6020.105	Module Width 600	Brown Metal Grey	583 x 448 x 200	525 x 390
FCS80.9020.105	Module Width 900	Brown Metal Grey	883 x 448 x 200	825 x 390

MOUNTING BRACKETS FOR DRAWER BOX H100 (drawer and slides sold separately)

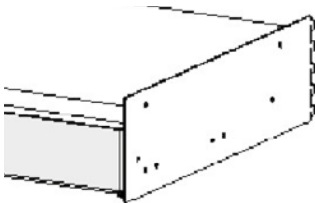

ITEM	SPECIFICATIONS	FINISH	DIMENSIONS (mm)
FCS81.5015.105	Left / Right / Central Application	Brown Metal Grey	500 x 156 x 3

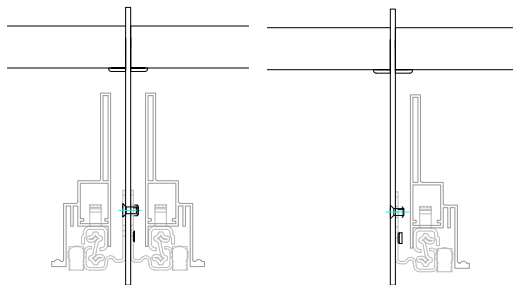

H100
Center mounted
slide configuration

H100
End mounted
slide configuration



GLASS/WOOD BOTTOM PANEL DIMENSION:

- DRAWER OUTSIDE DEPTH MINUS 58mm
- DRAWER OUTSIDE WIDTH MINUS 58mm
- THICKNESS 4mm

MOUNTING BRACKETS FOR DRAWER BOX H100/H200 (drawer and slides sold separately)

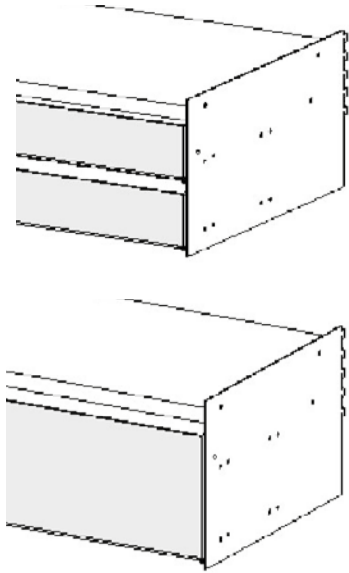

ITEM	SIDE	FINISH	DIMENSIONS (mm)
FCS81.5027.105	Left / Right / Central Application	Brown Metal Grey	500 x 276 x 3

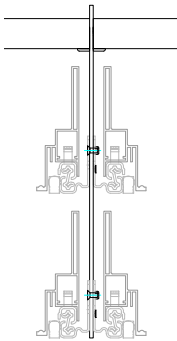
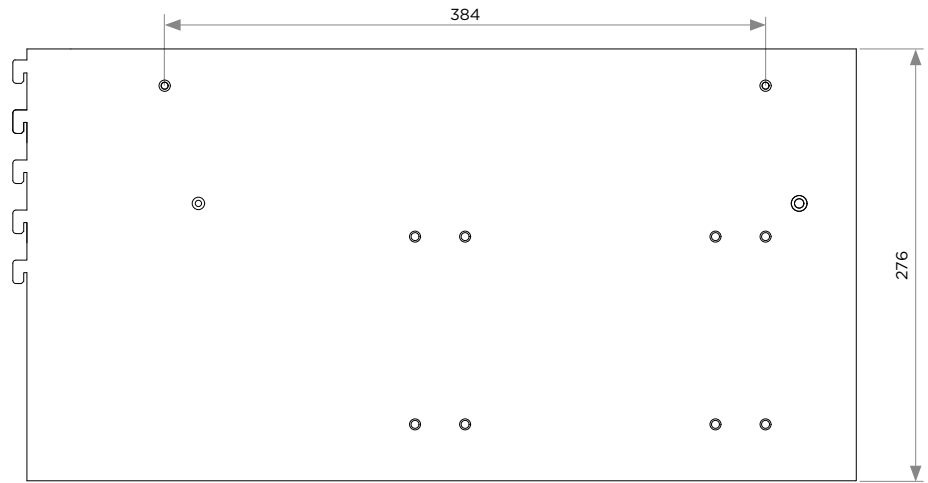

Double Stack - H100
Center mounted
slide configuration

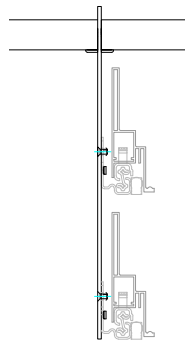

Double Stack - H100
End mounted
slide configuration

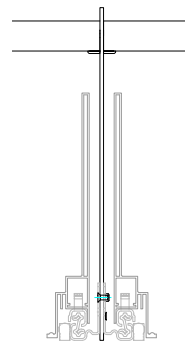

H200
Center mounted
slide configuration

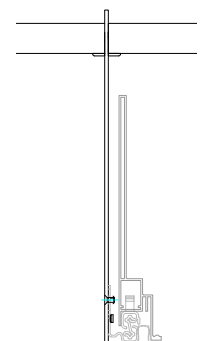

H200
End mounted
slide configuration

CONCEALED SLIDES WITH SOFT CLOSE FOR DRAWER BOXES



ITEM	SIDE	DIMENSIONS (mm)
FCS82R.420.001	Left	420
FCS82L.420.001	Right	420

TROUSER RACK FOR READY-MADE H100 DRAWER BOX

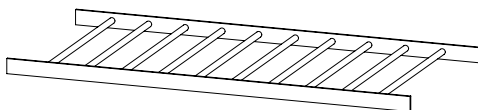

ITEM	SPECIFICATIONS	FINISH	DIMENSIONS (mm)
FCS83.5239.105	Module Width 600	Brown Metal Grey	525 x 390
FCS83.8238.105	Module Width 900	Brown Metal Grey	825 x 390

LINEN STORAGE BASKETS FOR READY-MADE H100 DRAWER BOX



ITEM	SPECIFICATIONS	FINISH	DIMENSIONS (mm)
FCS84.2239.004	To be ordered with frame	Smoke	226 x 390 x 420
FCS84.2239.005	To be ordered with frame	Mud	226 x 390 x 420
FCS84.2239.006	To be ordered with frame	Hay	226 x 390 x 420

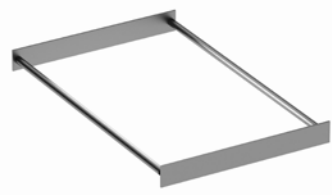

ITEM	SPECIFICATIONS	FINISH	DIMENSIONS (mm)
FCS84.2539.105	To be ordered with linen storage Baskets	Brown Metal Grey	250 x 390 x 30

MODULE WIDTH EXAMPLES



H100 Ready-Made Drawer
Module Width 600
(2) Frames &
(2) Linen Storage Baskets



H100 Ready-Made Drawer
Module Width 900
(3) Frames &
(3) Linen Storage Baskets

CABINET REAR MOUNT BRACKETS

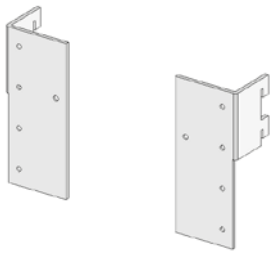
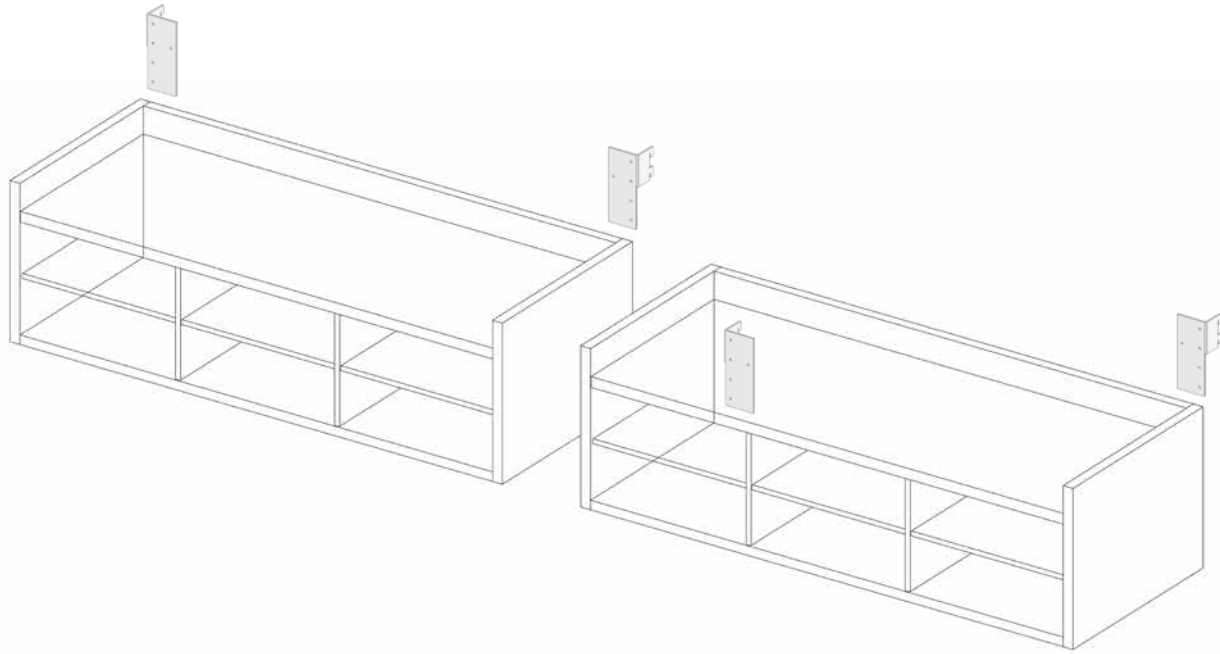

ITEM	SPECIFICATIONS	FINISH
FCS85.1205.105	Set of Right + Left	Brown Metal Grey

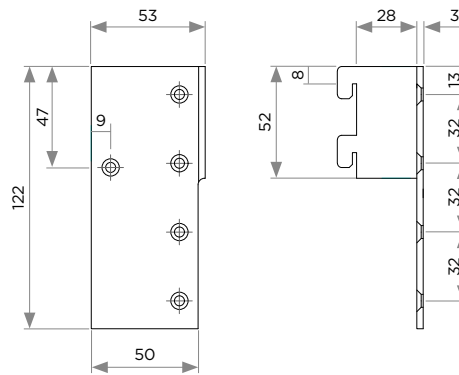

CABINET SIDE MOUNT BRACKETS

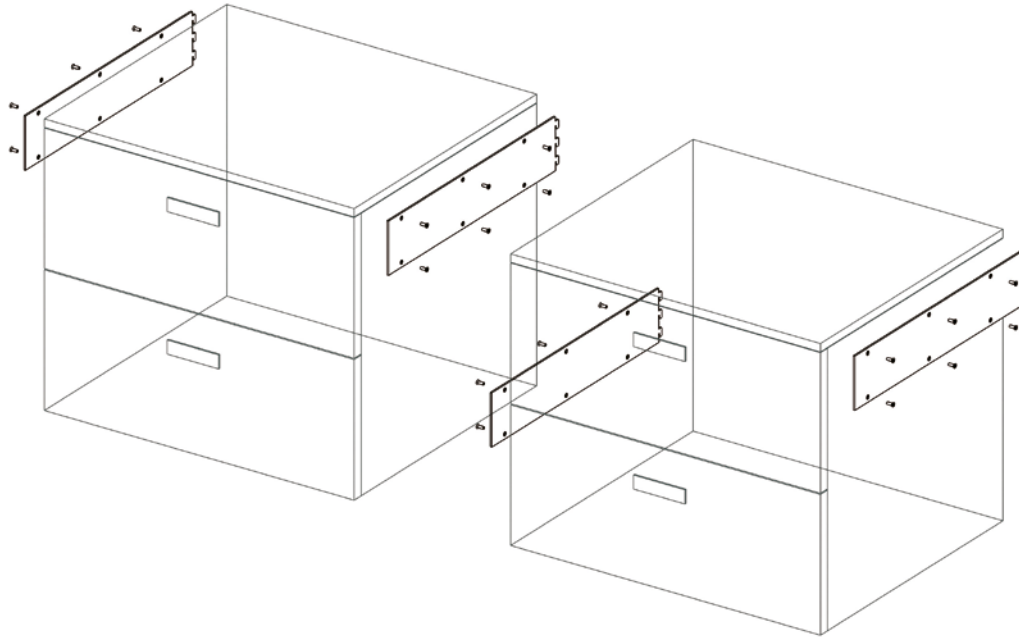

ITEM	SPECIFICATIONS	FINISH	DIMENSIONS (mm)
FCS85.4012.105	Left / Right / Central Application	Brown Metal Grey	400 x 124 x 3
FCS85.5012.105	Left / Right / Central Application	Brown Metal Grey	500 x 124 x 3

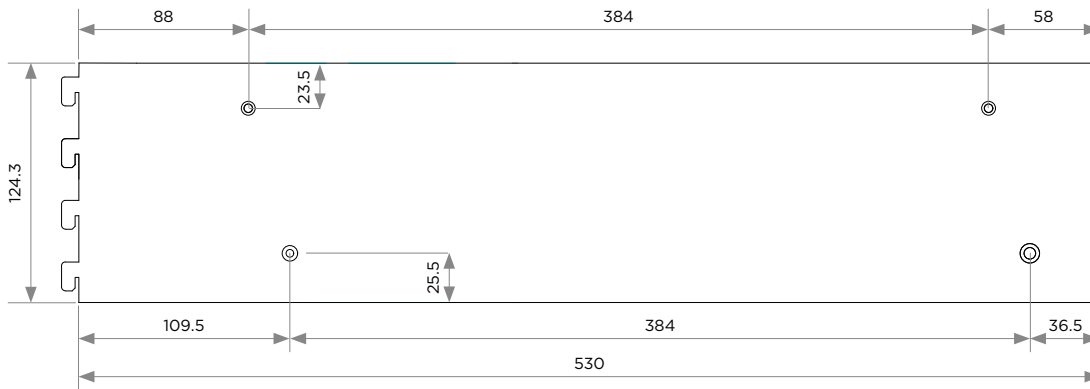

EXAMPLE OF APPLICATIONS

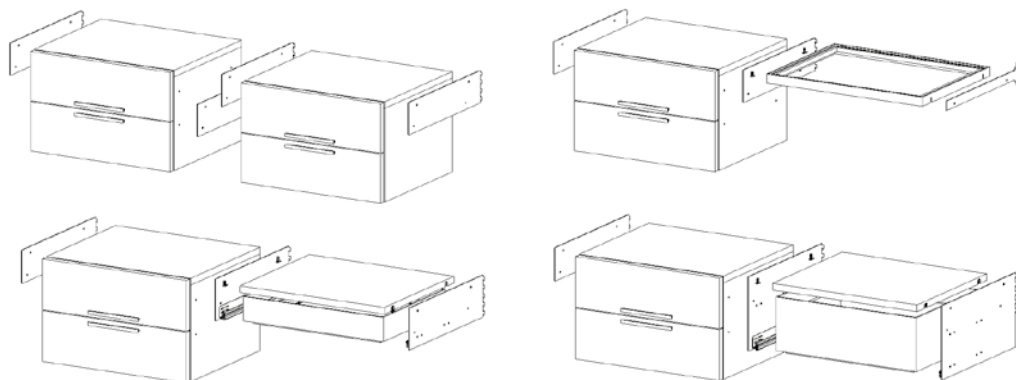

LIGHTING

RECESSED LIGHTING - CUT TO LENGTH (bottom side of shelf shown below)

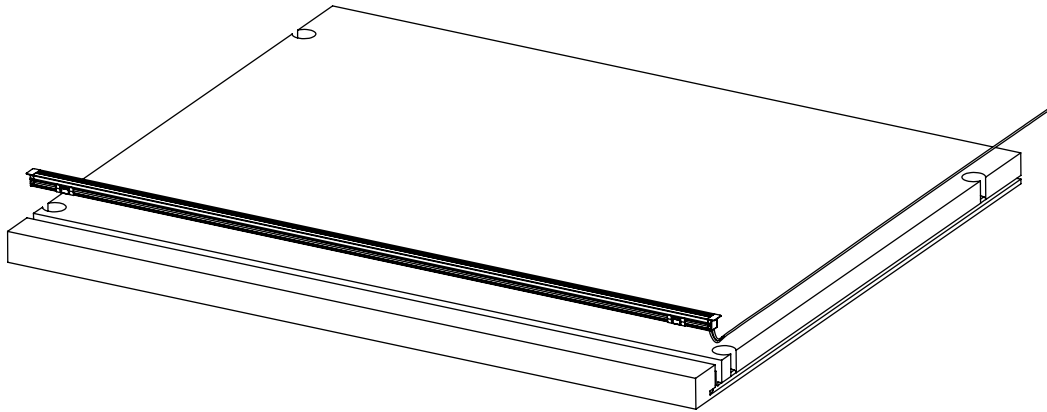

FACE BORING PANEL ROUTING DETAILS FOR POWER CORD TO EXIT FROM THE REAR OF SHELF (power exiting left shown below)

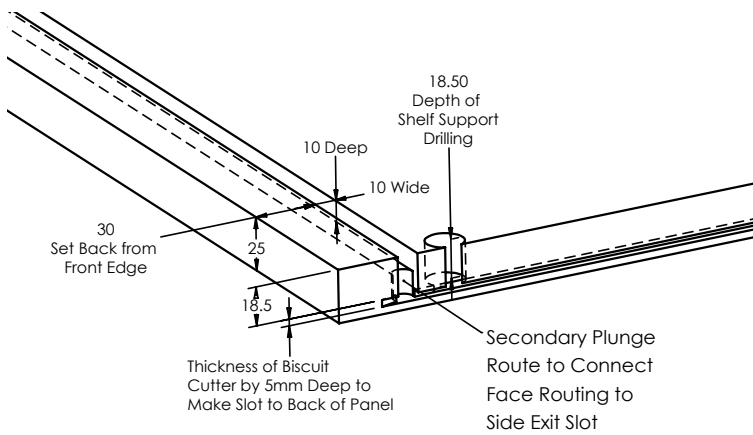

LUM11L.100.007 for Power Exiting Left
LUM11R.100.007 for Power Exiting Right
 Directional lighting to the rear of cabinet or shelf with an option of power to exit either to the left or right side of the shelf.

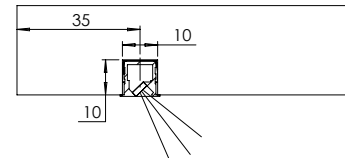

LUM10.100.007
 Non-directional lighting with power exiting to either right or left side of the shelf. (unhanded unit)

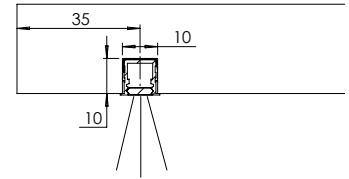

AVAILABLE SWITCHES

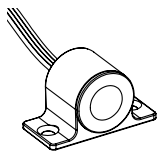

LUM12.005.0515
 Surface Mounted (PIR)
 Motion Sensor Switch

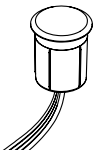

LUM12.006.007
 Recess Mounted Touch
 Switch and Dimmer



LUM12.007.003
 Surface Mounted
 Touch Switch and
 Dimmer

ITEM	SPECIFICATIONS	FINISH	DIMENSIONS (mm)
LUM10.100.007	Recessed Light Profile, 24V, 7.4 w/m, 3000K, Press Fit, Can be Trimmed to Length	Iron Grey	1000 x 10 x 10
LUM11L.100.007	Recessed Light Profile, Directional, Left, 24V, 7.4 w/m, 3000K, Press Fit, Can be Trimmed to Length	Iron Grey	1000 x 10 x 10
LUM11R.100.007	Recessed Light Profile, Directional, Right, 24V, 7.4 w/m, 3000K, Press Fit, Can be Trimmed to Length	Iron Grey	1000 x 10 x 10
LUM12.001.008	Wire Connecting Kit with End Caps for Recessed Lights	White	1500mm
LUM12.002.009	Stainless Steel Installation Brackets for Recessed Light, Pack of 10	Stainless	10 x 10 x 20
LUM12.005.0515	(PIR) Passive Infrared Motion Sensor Switch, 24V, Surface Mount	Black	28 x 14 x 16
LUM12.006.007	Button Style Dimmer Switch, 24V, Press Fit	Iron Grey	Ø14 x 16
LUM12.007.003	Pad Style Dimmer Switch, 24V, Surface Mount	White	43.5 x 7

ALUMINUM READY-MADE SHELF LIGHTING (front rail cross-sections shown below)

Front face of aluminum ready-made frame.

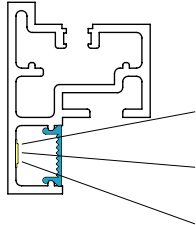

ITEM	SPECIFICATIONS	FINISH	DIMENSIONS (mm)
LUM12.009.003	Distribution Block , 6-Way, 24V, 1000mm	White	50 x 38 x 10
LUM12.008.003	Smart LDV LED Driver, Input Voltage: 100-240VAC -50-60Hz, Output Voltage: DC 24V < 4.16A 96w, 1500mm	White	210 x 62 x 18.5
LUM12.003.003	LED Tape Strip, 24V, 7.5 w/m, 4000K, Tape Mounted, 5000mm	White	5000 x 1 x 5
LUM12.004.003	LED Tape Strip Connecting Terminal, 24V, 150mm	White	150
LUM12.010.003	Connector Cable, Male/Female, 24V, 1500mm	White	1500
LUM12.011.015	Connector Cable, Male/Female, 24V, 1500mm	Black	1500
FCS72.300.003	Diffuser Lens for Aluminum Ready-Made Shelf	Translucent	1000 x 10 x 3

LED TAPE LIGHT INSTALLATION

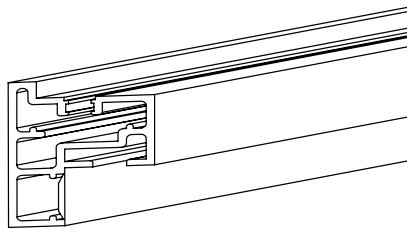

Step 1

- Remove aluminum snap-out-section of the front frame rail to reveal LED lighting cavity and lens mounting tabs.

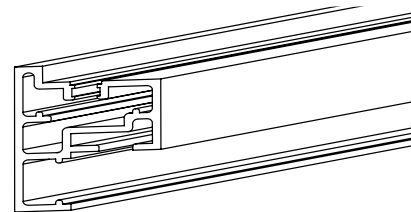

Step 2

- The vertical tape mounting surface and the diffuser lens mounting tabs will now be exposed.

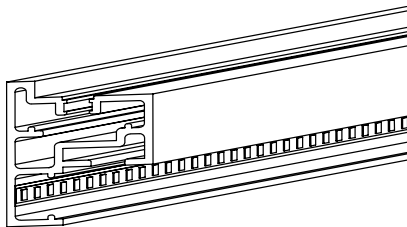

Step 3

- Cut the LED tape to length and install the fast connection terminal to one end.
- Firmly mount the LED strip inside the flat vertical surface using the peel & stick backside side of LED tape.

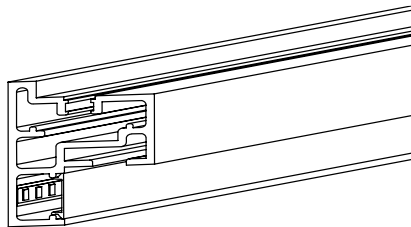

Step 4

- Snap the light diffuser lens into place covering the LED Tape.

Step 5

Run the power wire to the rear of the frame inside the LED cavity and through the rear exit hole.

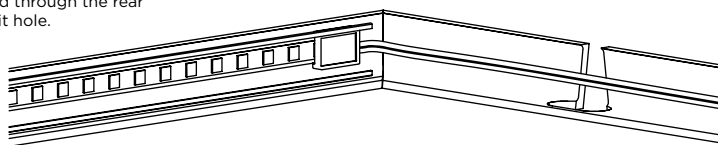

Cut-away view of the frame revealing the LED mounting and wiring cavity.





CONTACT INFO

1255 South Park Dr.
Kernersville, NC 27284 USA
Tel. 336-996-7774
Fax 336-996-1812
Toll Free 800-222-6941
E-mail: info@petermeier.com
www.petermeier.com

